

Imperial Inserts & Key Locking Inserts



www.spec-e.com
info@spec-e.com

ASTOR PLAZA TURGUT ÖZAL MAH.
1467/1 CAD. NO:42 /33(10)
06370
YENİMAHALLE/ANKARA

Solution

Partner

in

Engineering

Challenges

Table of Contents

03 18-8 Stainless Steel Inserts

06 Black-Phosphate Steel Inserts

09 Mil-Spec Stainless Steel Inserts

11 Mil- Spec Alloy Steel Inserts

13 Screw-Locking Inserts



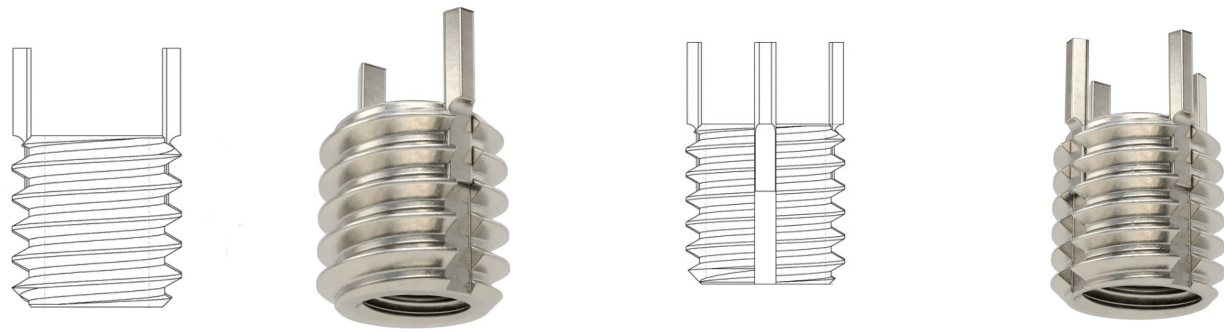

18-8 Stainless Steel with Thin Wall Inserts

Thread Size	For Tap Thread Size	Installed Length	Drill Bit Size	For Max. Hole Dia	Number of Locking Keys
10-32	5/16"-18	5/16"	I	0.272"	2
10-24	5/16"-18	5/16"	I	0.272"	2
1/4"-20	3/8"-16	3/8"	Q	0.332"	2
1/4"-28	3/8"-16	3/8"	Q	0.332"	2
5/16"-18	7/16"-14	7/16"	X	0.397"	4
5/16"-24	7/16"-14	7/16"	X	0.397"	4
3/8"-16	1/2"-13	1/2"	29/64"	0.453"	4
3/8"-24	1/2"-13	1/2"	29/64"	0.453"	4
7/16"-14	9/16"-12	9/16"	33/64"	0.516"	4
7/16"-20	9/16"-12	9/16"	33/64"	0.516"	4
1/2"-13	5/8"-11	5/8"	37/64"	0.578"	4
1/2"-20	5/8"-11	5/8"	37/64"	0.578"	4

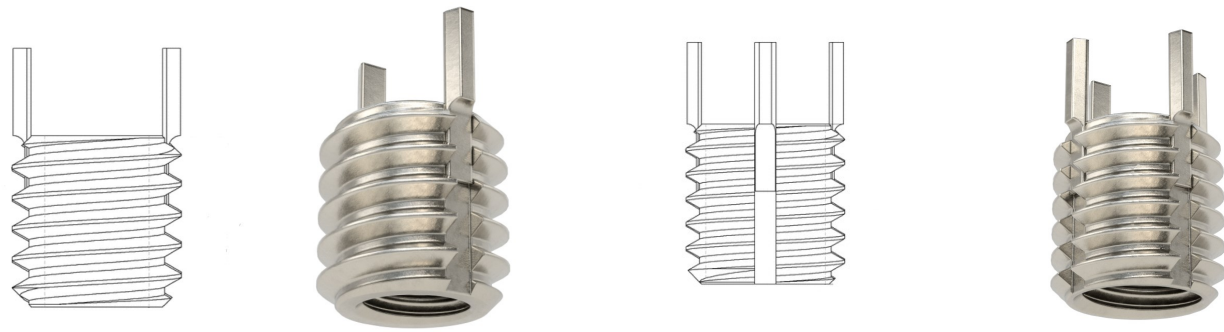

18-8 Stainless Steel with Thick Wall Inserts

Thread Size	For Tap Thread Size	Installed Length	Drill Bit Size	For Max. Hole Dia	Number of Locking Keys
8-32	5/16"-18	5/16"	I	0.272"	2
10-24	3/8"-16	5/16"	Q	0.332"	2
10-32	3/8"-16	5/16"	Q	0.332"	2
1/4"-20	7/16"-14	3/8"	X	0.397"	2
1/4"-28	7/16"-14	3/8"	X	0.397"	2
5/16"-18	1/2"-13	7/16"	29/64"	0.453"	4
5/16"-24	1/2"-13	7/16"	29/64"	0.453"	4
3/8"-16	9/16"-12	1/2"	33/64"	0.516"	4
3/8"-24	9/16"-12	1/2"	33/64"	0.516"	4
7/16"-14	5/8"-11	5/8"	37/64"	0.578"	4
7/16"-20	5/8"-11	5/8"	37/64"	0.578"	4
1/2"-13	3/4"-16	5/8"	45/64"	0.703"	4
1/2"-20	3/4"-16	5/8"	45/64"	0.703"	4
9/16"-12	3/4"-16	13/16"	45/64"	0.703"	4

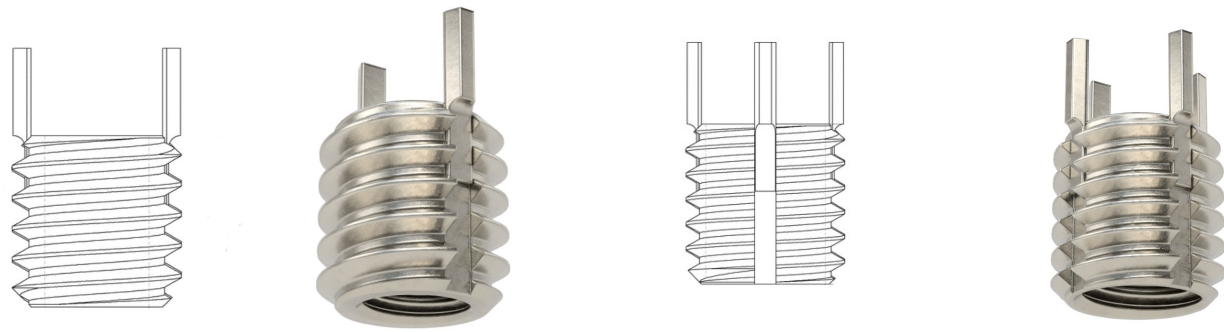

18-8 Stainless Steel with Thick Wall Inserts

Thread Size	For Tap Thread Size	Installed Length	Drill Bit Size	For Max. Hole Dia	Number of Locking Keys
9/16"-18	3/4"-16	13/16"	45/64"	0.703"	4
5/8"-11	7/8"-14	7/8"	53/64"	0.828"	4
5/8"-18	7/8"-14	7/8"	53/64"	0.828"	4
3/4"-10	1 1/8"-12	1 1/8"	1 1/16"	1.063"	4
3/4"-16	1 1/8"-12	1 1/8"	1 1/16"	1.063"	4
7/8"-9	1 1/4"-12	1 1/4"	1 3/16"	1.188"	4
7/8"-14	1 1/4"-12	1 1/4"	1 3/16"	1.188"	4
1"-8	1 3/8"-12	1 3/8"	1 5/16"	1.313"	4
1"-12	1 3/8"-12	1 3/8"	1 5/16"	1.313"	4

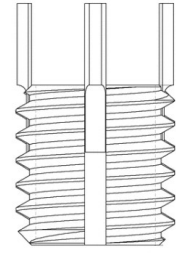
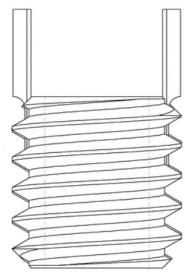

Black-Phosphate Steel Key-Locking Inserts

Thread Size	For Tap Thread Size	Installed Length	Drill Bit Size	For Max. Hole Dia	Number of Locking Keys
10-32	5/16"-18	5/16"	I	0.272"	2
10-24	5/16"-18	5/16"	I	0.272"	2
1/4"-20	3/8"-16	3/8"	Q	0.332"	2
1/4"-28	3/8"-16	3/8"	Q	0.332"	2
5/16"-18	7/16"-14	7/16"	X	0.397"	4
5/16"-24	7/16"-14	7/16"	X	0.397"	4
3/8"-16	1/2"-13	1/2"	29/64"	0.453"	4
3/8"-24	1/2"-13	1/2"	29/64"	0.453"	4
7/16"-14	9/16"-12	9/16"	33/64"	0.516"	4
7/16"-20	9/16"-12	9/16"	33/64"	0.516"	4
1/2"-13	5/8"-11	5/8"	37/64"	0.578"	4
1/2"-20	5/8"-11	5/8"	37/64"	0.578"	4

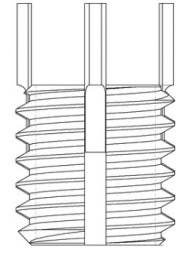
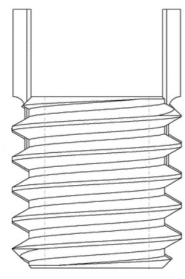

Black-Phosphate Steel Key-Locking Inserts

Thread Size	For Tap Thread Size	Installed Length	Drill Bit Size	For Max. Hole Dia	Number of Locking Keys
8-32	5/16"-18	5/16"	I	0.272"	2
10-24	3/8"-16	5/16"	Q	0.332"	2
10-32	3/8"-16	5/16"	Q	0.332"	2
1/4"-20	7/16"-14	3/8"	X	0.397"	2
1/4"-28	7/16"-14	3/8"	X	0.397"	2
5/16"-18	1/2"-13	7/16"	29/64"	0.453"	4
5/16"-24	1/2"-13	7/16"	29/64"	0.453"	4
3/8"-16	9/16"-12	1/2"	33/64"	0.516"	4
3/8"-24	9/16"-12	1/2"	33/64"	0.516"	4
7/16"-14	5/8"-11	5/8"	37/64"	0.578"	4
7/16"-20	5/8"-11	5/8"	37/64"	0.578"	4
1/2"-13	3/4"-16	5/8"	45/64"	0.703"	4
1/2"-20	3/4"-16	5/8"	45/64"	0.703"	4
9/16"-12	3/4"-16	13/16"	45/64"	0.703"	4

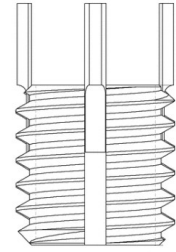
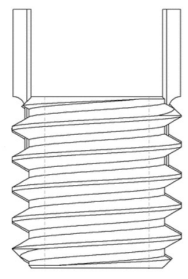

Black-Phosphate Steel Key-Locking Inserts

Thread Size	For Tap Thread Size	Installed Length	Drill Bit Size	For Max. Hole Dia	Number of Locking Keys
9/16"-18	3/4"-16	13/16"	45/64"	0.703"	4
5/8"-11	7/8"-14	7/8"	53/64"	0.828"	4
5/8"-18	7/8"-14	7/8"	53/64"	0.828"	4
3/4"-10	1 1/8"-12	1 1/8"	1 1/16"	1.063"	4
3/4"-16	1 1/8"-12	1 1/8"	1 1/16"	1.063"	4
7/8"-9	1 1/4"-12	1 1/4"	1 3/16"	1.188"	4
7/8"-14	1 1/4"-12	1 1/4"	1 3/16"	1.188"	4
1"-8	1 3/8"-12	1 3/8"	1 5/16"	1.313"	4
1"-12	1 3/8"-12	1 3/8"	1 5/16"	1.313"	4

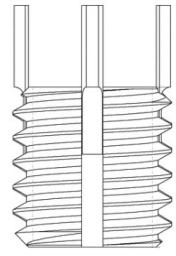
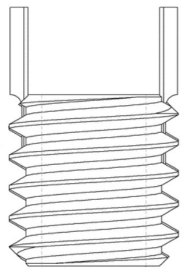

Mil Spec Stainless Steel Key-Locking Inserts

Thread Size	For Tap Thread Size	Installed Length	Drill Bit Size	For Max. Hole Dia	Number of Locking Keys	Specifications Met
2-56	8-32	1/8"	29	0.137"	2	MS51830-101
4-40	10-32	11/64"	20	0.164"	2	MS51830-102
4-40	12-24	1/4"	14	0.183"	2	NAS1395C04
6-32	12-28	11/64"	3/16"	0.19"	2	MS51830-103
6-32	1/4"-20	1/4"	7/32"	0.216"	2	NAS1395C06
8-32	1/4"-20	1/4"	7/32"	0.216"	2	NAS1394C08
8-32	1/4"-28	7/32"	15/64"	0.231"	2	MS51830-104
10-24	5/16"-18	5/16"	I	0.276"	2	MS51830-105
10-32	5/16"-18	5/16"	I	0.276"	2	MS51830-201, NAS1394C3
1/4"-20	3/8"-16	3/8"	Q	0.336"	2	MS51830-106

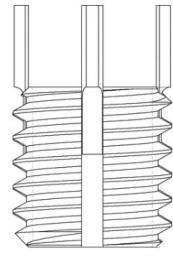
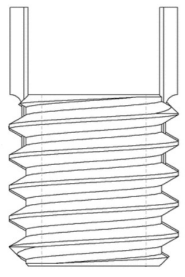

Mil-Spec Stainless Steel Key-Locking Inserts

Thread Size	For Tap Thread Size	Installed Length	Drill Bit Size	For Max. Hole Dia	Number of Locking Keys	Specifications Met
1/4"-28	3/8"-16	3/8"	Q	0.336"	2	MS51830-202, NAS1394C4
5/16"-18	7/16"-14	7/16"	X	0.401"	4	MS51830-107
5/16"-24	7/16"-14	7/16"	X	0.401"	4	MS51830-203, NAS1394C5
3/8"-16	1/2"-13	1/2"	29/64"	0.457"	4	MS51830-108
3/8"-24	1/2"-13	1/2"	29/64"	0.457"	4	MS51830-204, NAS1394C6
7/16"-20	9/16"-12	9/16"	33/64"	0.521"	4	MS51830-205, NAS1394C7
1/2"-13	5/8"-11	5/8"	37/64"	0.583"	4	MS51830-110
1/2"-20	5/8"-11	5/8"	37/64"	0.583"	4	MS51830-206, NAS1394C8

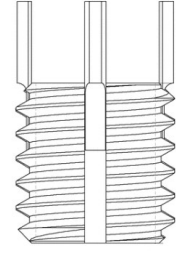
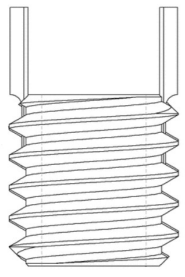

Mil-Spec Alloy Steel Key-Locking Inserts

Thread Size	For Tap Thread Size	Installed Length	Drill Bit Size	For Max. Hole Dia	Number of Locking Keys	Specifications Met
2-56	8-32	1/8"	29	0.137"	2	MS51830-101
4-40	10-32	11/64"	20	0.164"	2	MS51830-102
4-40	12-24	1/4"	14	0.183"	2	NAS1395C04
6-32	12-28	11/64"	3/16"	0.19"	2	MS51830-103
6-32	1/4"-20	1/4"	7/32"	0.216"	2	NAS1395C06
8-32	1/4"-20	1/4"	7/32"	0.216"	2	NAS1394C08
8-32	1/4"-28	7/32"	15/64"	0.231"	2	MS51830-104
10-24	5/16"-18	5/16"	I	0.276"	2	MS51830-105
10-32	5/16"-18	5/16"	I	0.276"	2	MS51830-201, NAS1394C3
1/4"-20	3/8"-16	3/8"	Q	0.336"	2	MS51830-106

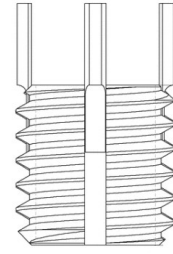
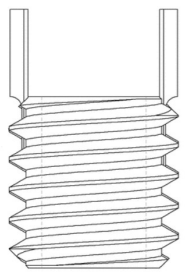

Mil-Spec Alloy Steel Key-Locking Inserts

Thread Size	For Tap Thread Size	Installed Length	Drill Bit Size	For Max. Hole Dia	Number of Locking Keys	Specifications Met
1/4"-28	3/8"-16	3/8"	Q	0.336"	2	MS51830-202, NAS1394C4
5/16"-18	7/16"-14	7/16"	X	0.401"	4	MS51830-107
5/16"-24	7/16"-14	7/16"	X	0.401"	4	MS51830-203, NAS1394C5
3/8"-16	1/2"-13	1/2"	29/64"	0.457"	4	MS51830-108
3/8"-24	1/2"-13	1/2"	29/64"	0.457"	4	MS51830-204, NAS1394C6
7/16"-20	9/16"-12	9/16"	33/64"	0.521"	4	MS51830-205, NAS1394C7
1/2"-13	5/8"-11	5/8"	37/64"	0.583"	4	MS51830-110
1/2"-20	5/8"-11	5/8"	37/64"	0.583"	4	MS51830-206, NAS1394C8

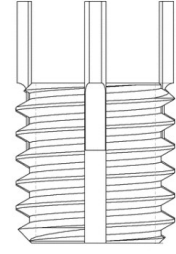
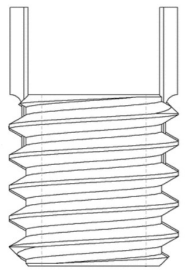

Screw-Locking Key-Locking Inserts

Thread Size	For Tap Thread Size	Installed Length	Drill Bit Size	For Max. Hole Dia	Number of Locking Keys	Specifications Met
2-56	8-32	1/8"	29	0.137"	2	MS51830-101
4-40	10-32	11/64"	20	0.164"	2	MS51830-102
4-40	12-24	1/4"	14	0.183"	2	NAS1395C04
6-32	12-28	11/64"	3/16"	0.19"	2	MS51830-103
6-32	1/4"-20	1/4"	7/32"	0.216"	2	NAS1395C06
8-32	1/4"-20	1/4"	7/32"	0.216"	2	NAS1394C08
8-32	1/4"-28	7/32"	15/64"	0.231"	2	MS51830-104
10-24	5/16"-18	5/16"	I	0.276"	2	MS51830-105
10-32	5/16"-18	5/16"	I	0.276"	2	MS51830-201, NAS1394C3
1/4"-20	3/8"-16	3/8"	Q	0.336"	2	MS51830-106

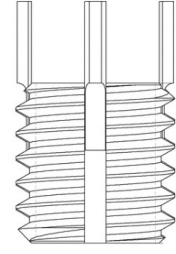
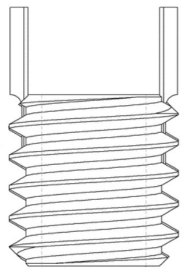

Screw-Locking Key-Locking Inserts

Thread Size	For Tap Thread Size	Installed Length	Drill Bit Size	For Max. Hole Dia	Number of Locking Keys	Specifications Met
1/4"-28	3/8"-16	3/8"	Q	0.336"	2	MS51830-202, NAS1394C4
5/16"-18	7/16"-14	7/16"	X	0.401"	4	MS51830-107
5/16"-24	7/16"-14	7/16"	X	0.401"	4	MS51830-203, NAS1394C5
3/8"-16	1/2"-13	1/2"	29/64"	0.457"	4	MS51830-108
3/8"-24	1/2"-13	1/2"	29/64"	0.457"	4	MS51830-204, NAS1394C6
7/16"-20	9/16"-12	9/16"	33/64"	0.521"	4	MS51830-205, NAS1394C7
1/2"-13	5/8"-11	5/8"	37/64"	0.583"	4	MS51830-110
1/2"-20	5/8"-11	5/8"	37/64"	0.583"	4	MS51830-206, NAS1394C8

FOR MORE INFORMATION,
PLEASE CONTACT US.

www.spec-e.com
info@spec-e.com

ASTOR PLAZA TURGUT ÖZAL MAH.
1467/1 CAD. NO:42 /33(10)
06370
YENİMAHALLE/ANKARA